



Turner Uni-Drive

20M — Manual Shift

Ratio range 1.00 - 2.62 : 1
Torque Capacity - 4250 in-lbs (Manual)

Approx. Weight 340 lbs

2, 3, 4, and 6 speeds with manual shift
2 or 4 speeds with pneumatic shift
Off-the-shelf components for all ratios
Available with reversing ratios

DIMENSIONS

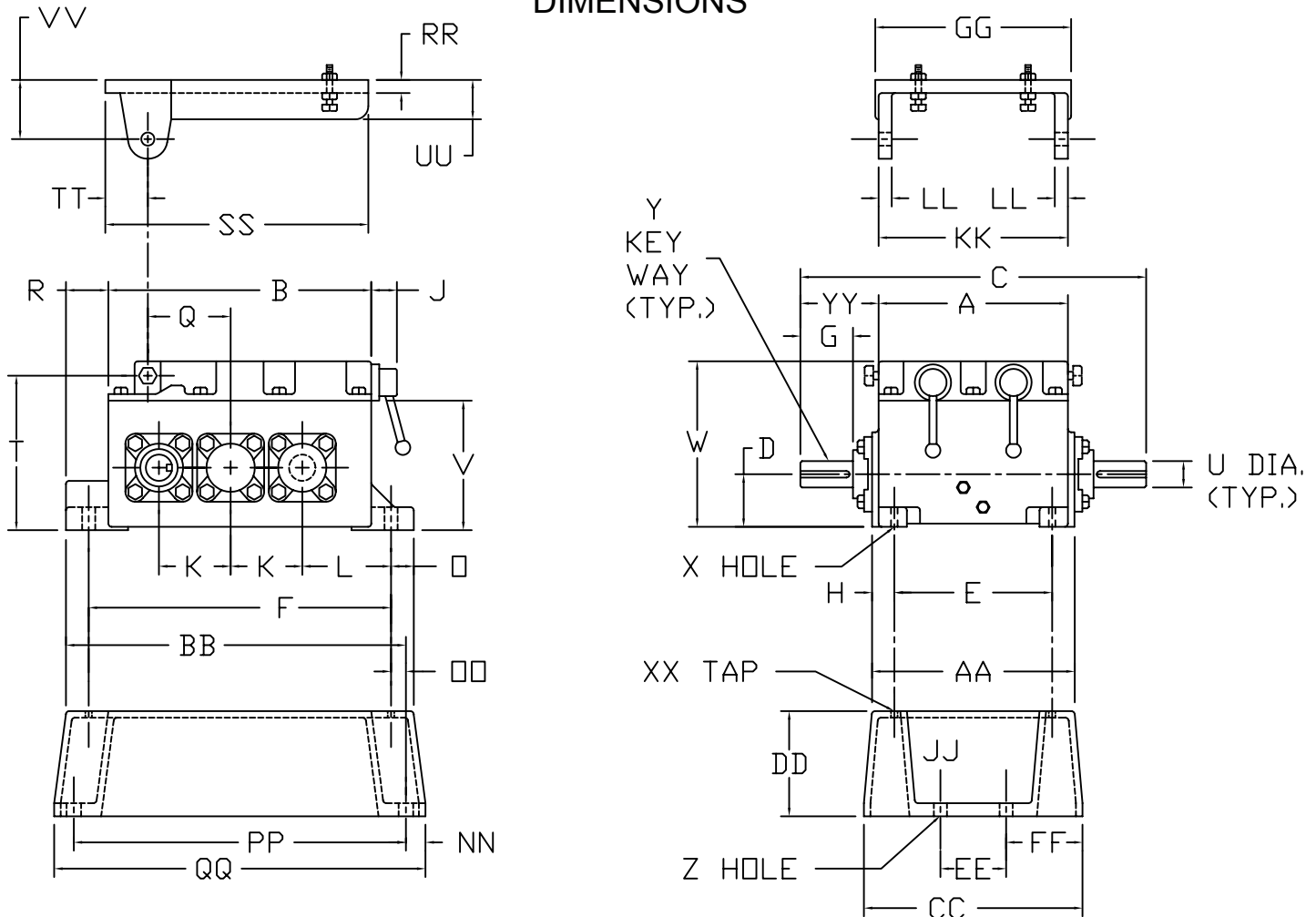

A	B	C	D	E	F	G	H	J	K	L	□
15	17 1/4	27 1/4	4,250	10 3/4	20 1/8	5	2 1/8	1 5/8	5,000	5 1/16	15/16

Q	R	T	U	V	W	X	Y	Z
7 1/8	2 3/8	10 13/16	2,250	8 13/16	11 13/16	7/8 DIA	1/2 X 1/4 X 4 1/2	7/8 DIA

AA	BB	CC	DD	EE	FF	GG	JJ	KK	LL	NN	□□
15	22 1/8	15 1/2	6,000	5	5 1/4	15 3/8	2 7/8	14 5/8	1	1 1/4	1/8

PP	QQ	RR	SS	TT	UU	VV	XX	YY
20 3/8	22 7/8	5/8	17	2 5/8	1 5/8	5	3/4-10 NC THREAD	6 1/8

DIMENSIONS ARE IN INCHES AND ARE NOT TO BE USED FOR CONSTRUCTION UNLESS CERTIFIED