



# Turner Uni-Drive

## 55M-SR Manual Shift

Ratio range 1.00 - 2.50 : 1  
Torque Capacity - 40,000 in-lbs

2 & 3 speeds with manual or pneumatic shift

Approx. Weight 1200 lbs

### DIMENSIONS

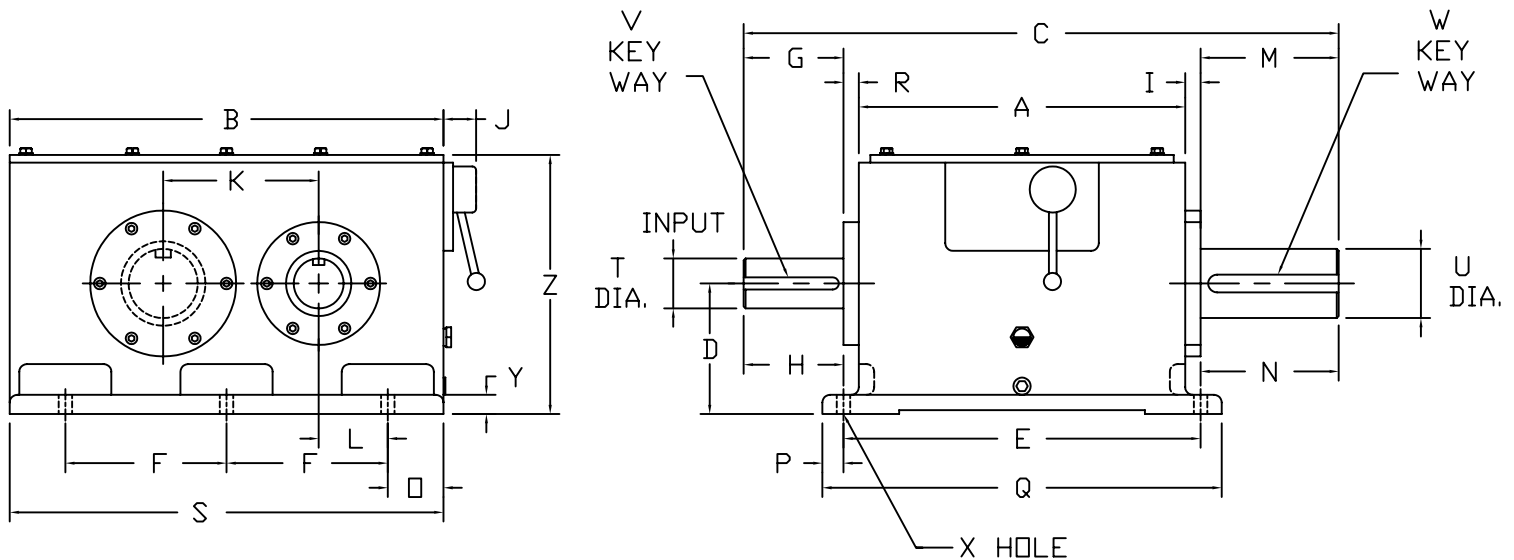

Center Distance Between Shafts, Shaft Diameters, and Distance from Center Line of Shaft to Base May Vary Depending on Application.

Hinged Motor Plate and Mounting Base available as Optional Accessories. Contact TURNER UNI-DRIVE for Dimensions.

A	B	C	D	E	F	G	H	I	J	K	L
21 1/4	28 1/4	38 3/4	8.500	23 1/4	10 1/2	6 1/2	6 1/2	1	3	10.125	4.500
M	N	□	P	Q	R	S	T	U			
9	9	3 5/8	1 3/8	26	1	28 1/4	3.250	4.500			
V			W			X	Y	Z			
3/4 X 3/8 X 6			1 X 1/2 X 8 1/2			7/8 DIA	1 1/4	16 7/8			

DIMENSIONS ARE IN INCHES AND ARE NOT TO BE USED FOR CONSTRUCTION UNLESS CERTIFIED